

Jager

Thank you for purchasing Jager Match Scope Rings.

Our Match Scope Rings are manufactured to the highest standards and tolerances.

The rings are precision-machined on advanced 5-axis CNC equipment to minimize manufacturing operations and ensure exceptional accuracy, consistency, and quality.

Installation Instructions

Position the rings on the Picatinny rail and tighten the base screws until each ring is firmly secured to the rail without any movement.

Place the riflescope in the rings and assume your normal shooting position. Adjust the scope to achieve proper eye relief and ensure that the vertical crosshair is aligned with the rifle's vertical axis.

The use of a scope-leveling system is recommended.

Install the top caps and tighten the eight cap screws evenly in the sequence shown.

Gradually tighten the screws while maintaining equal gaps on both sides of each ring cap.

Final torque should be 18 in-lb.

Torque Specifications

Ring Cap Screws: 18 in-lb

Base Clamp : Maximum recommended torque.

Do not exceed 30 in-lb.

Technical Support

For technical assistance or additional information,

Contact Jager Technical Service at

support@gunstuff.co.za or consult your local dealer.

Diagrams

1. Overview

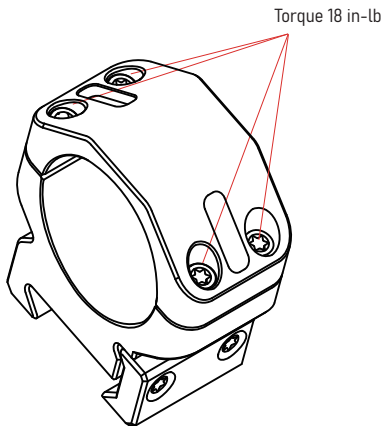

2. Screw Tightening Sequence

